

S9031RT-HC/S9043RT-HC

ULTRA-HIGH CAPACITY ROUGH TERRAIN SCISSOR LIFTS



- Ultra-high capacity, large deck rough terrain scissor lifts
- Excellent rough terrain performance
- Heavy duty design
- Dual powered extension decks
- Ideal for construction applications

 **snorkel**[™]
www.snorkellifts.com

ULTRA-HIGH CAPACITY ROUGH TERRAIN SCISSOR LIFTS

S9031RT-HC/ S9043RT-HC

DIMENSIONS	S9031RT-HC*	S9043RT-HC*
Max. working height	11.4m	15.1m
Max. platform height (A)	9.4m	13.1m
Platform size (stowed)	2.28m x 4.87m	
Platform size (dual decks extended)	2.28m x 8.23m	
Extension deck length	1.37m	1.37m
Overall width (B)	2.28m	2.28m
Overall length (D)	4.87m	4.87m
Stowed height (C)	2.77m	2.77m
Min. height (guardrails folded)	1.9m	1.9m
Ground clearance	356mm	356mm

PERFORMANCE	S9031RT-HC*	S9043RT-HC*
Platform capacity (SWL)	1,814kg	1,587kg
Max. drive height	9.4m	13.1m
Max. wind speed	12.5m/s	12.5m/s
Max. drive speed (stowed)	6.7km/h	6.7km/h
Max. drive speed (elevated)	0.96km/h	0.96km/h
Raise/lower time	30/20 sec	40/25 sec
Gradeability	50%	50%
Max. stabilizer levelling, front to rear	6°	6°
Max. stabilizer levelling, side to side	14°	12°
Inside turning radius	2.4m	2.4m
Outside turning radius	5.6m	5.6m
Tires	13 x 36 foam filled	
Controls	proportional joystick	
Drive system	4-wheel drive	

POWER	S9031RT-HC*	S9043RT-HC*
Power source	Kubota diesel engine	

WEIGHT	S9031RT-HC*	S9043RT-HC*
Weight	6,803kg	7,711kg

TURNING RADIUS

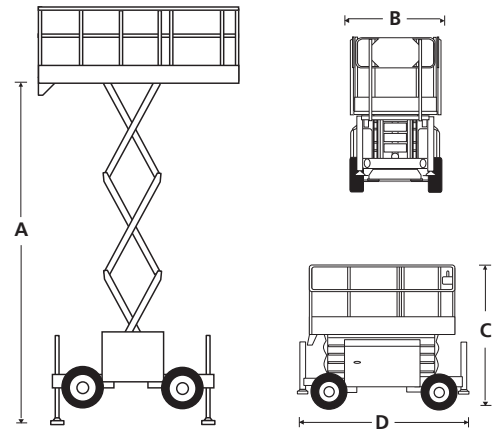
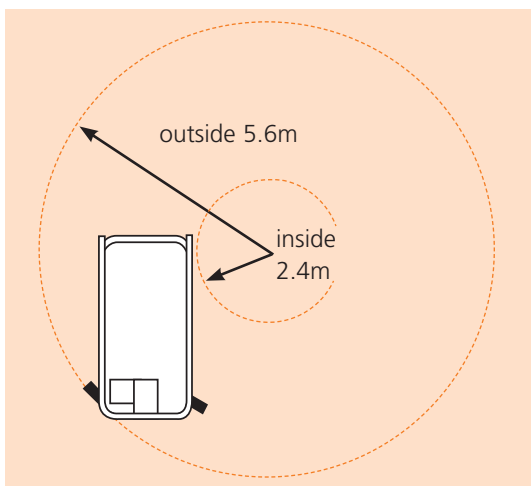

STANDARD FEATURES

- 4-wheel drive
- 4 hydraulic stabilizers with automatic levelling
- Dual powered extension decks
- Proportional controls
- Foam filled tires
- Power line to platform
- Platform overload system
- Drive motion alarm
- Descent alarm
- Locking oscillating axle
- Manual lowering valve
- Flashing amber light
- Fold down guardrails
- Dual lanyard attachment points
- Hour meter & on-board diagnostics display
- 2 year parts & labor, 5 year structural warranty
- ANSI compliant

OPTIONS

- Special paint colors
- Non-marking foam filled tires
- Nylon spreader pads (set of 4)
- Environmental hydraulic oil
- Cold weather package (block heater + battery warm up)
- Hydraulic generator 110V 2kW
- 12kW generator package

snorkel www.snorkellifts.com

P.O. Box 1160
St. Joseph, MO 64502-1160, USA
Tel: 1 (785) 989-3000
Toll-free: 1 (800) 255-0317
Fax: 1 (785) 989-3070
Email: sales.usa@snorkellifts.com